

Irons and Ironing Tables



You should not do without these Advantages for any Ironing Table.



Stabilizing cold ironing technology
By thoroughly cooling the garment, the applied shape is set quickly, reliably and permanently. The benefits of the VEIT cold ironing technology can be seen in every VEIT ironing table.



Energy-saving technology
Due to the superior suction of the VEIT ironing tables, the ironing surface is always dry. This normally enables the use of ironing bucks without heating. You save energy and your operating expenses are noticeably lower than with ironing tables which require heating due to inferior construction.



Superior and consistent suction power
For ironing, consistent strong suction across the entire ironing surface is particularly important. The aero dynamic design of the air guidance system, which VEIT has developed for its ironing stations, guarantees excellent and even suction across the entire ironing surface with a minimum noise level.



Adjustable blowing volume
This function guarantees excellent ironing results on all VEIT suction and blowing tables. The suction and blowing volume of Varioset ironing tables are independently of each other operate infinitely variable, and therefore, they assure the very best adaptation to all different kinds of materials. Especially on sensitive fabrics and linings, the blowing unit with its "air cushion" effect ensures excellent ironing results without pressure marks.

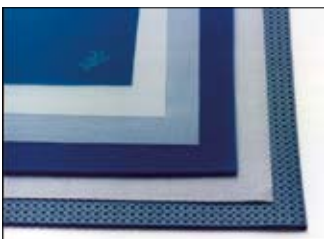

The Cover System

With ordinary ironing tables, the force of the suction deteriorates as the foam cover either becomes blocked or has collapsed after a few weeks of use and is no longer allowing air to pass through.

VEIT ironing tables have a base layer (Vakufitt) made of silicone which is easy to clean, permanently elastic and therefore practically free from wear. The intermediate layer of the VEIT cover consists of a special foam, also, which remains elastic much longer than conventional foam. Therefore, you always have optimal suction and blowing power with reduced operating expenses.





Automatic change-over

The suction is transferred automatically from the ironing surface to the swivelarm when the swivelarm is moved. The suction is diverted completely to the swivelarm so that our internationally proven cold ironing system, can also be applied there. This eliminates the need to activate a lever or flap, so you can continue working with practically no interruptions.

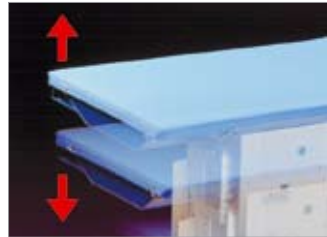

Optimal ergonomics

Everyone is different. Therefore, the height of the VEIT ironing tables can be adjusted to suit every operator guaranteeing fatigue-free working.



Selective suction

The ergonomic kicker plate is ideally placed to allow the suction to be used selectively. This gives much better ironing results than permanent suction and also saves energy. Sensitive fabrics can also be finished without leaving marks or shine.



Trouble-free operation

The VEIT name is renowned for its high quality products. From the motor and electronics to the high quality and hard wearing cover materials, all components meet the highest standards. This guarantees trouble-free operation, easy maintenance and long working life.



VEIT 2003 Iron Series

The iron generation 2003 developed from the successful iron series VEIT 2000 and 2002 is setting new standards where steam quality and precise steam direction are concerned. The well-engineered construction assures a high level of operational safety, long working life, top ergonomic design as well as excellent steam quality, even at low ironing temperatures.

Features of the VEIT 2003 irons

- Consistent steam quality for constant use.
- Temperature control accurate within $\pm 2^{\circ}\text{C}$ ($\pm 3^{\circ}\text{F}$) to iron temperature sensitive fabrics without marks
- Iron sole, high quality and especially smooth, is suitable for ironing without teflon frame sole
- Ergonomically shaped iron handle with a soft-touch microswitch to release steam.
- Integrated steam and heat protection for comfortable and safe ironing.



High-Pressure Iron VEIT HP 2003

The electronically controlled temperature regulation and the special chamber system of the ironing sole provide a condensate-free steam quality. These high pressure irons are optimally suitable for ironing of sensitive fabrics by its exceptionally smooth steam distribution and the accurate temperature control. The pointed design of the ironing sole guarantees an excellent ironing result even for areas which are difficult to access.

- Weight approx. 1275 grammes (approx. 3 lbs.).
230 Volt 1250 Watt 50-60 Hz
ironing surface 220 x 105 mm / 8.7 x 4 inch

Opening seams correctly:

For ironing of seams, a specially designed iron is advantageous (e.g. VEIT HS 2003). The narrow sole of the seam iron and the arched and narrow ironing buck avoid marks on the garment (see sketch).

For ironing fabrics that are sensitive to shine, we recommend using a teflon sole. The teflon reduces the contact temperature by up to 40°C and therefore prevents shine.

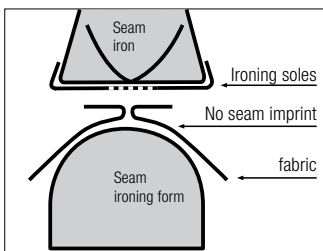

High-Pressure Seam Iron VEIT HS 2003

This iron is especially designed for ironing seams during underpressing. The extra flat point and the inclined steam outlet directed to the front guarantee easy opening of the seams. The narrow shape of the soleplate saves energy and directs it exactly to the right place.

- Weight approx. 1200 grammes (2.6 lbs.)
230 Volt 400 Watt 50-60 Hz
ironing surface 200 x 40 mm / 7.9 x 1.6 inch

Features VEIT 2128:

- Controlled by thermostat (temperature tolerance approx. +/- 15°C)
- Ergonomically shaped iron handle with integrated contactor to release steam
- Heavy duty ironing sole which glides smoothly over the fabric



High-Pressure Iron VEIT 2128

Low-priced robust iron suitable for all kinds of standard ironing.

- Weight approx. 1900 grammes (4.2 lbs.)
- 230 Volt 800 Watt 50-60 Hz
- ironing surface 200 x 115 mm / 7.9 x 4.5 inch



Standard Ironing Sole

- Smaller radius on the edges of the sole



Ironing soles for Dry Irons

- Larger radius on the edges of the sole



Dry Iron VEIT DI 2003

This ergonomically shaped dry iron with its specially coated aluminium soleplate glides smoothly over the fabric.

It is especially designed for ironing of lining. The specially rounded edges of the sole ensure that the lining is not displaced. A wrinkle-free ironing result is guaranteed.

- Weight approx. 1300 grammes (2.9 lbs.)
- 230 Volt 1250 Watt 50-60 Hz
- ironing surface 220 x 105 mm / 8.7 x 4 inch

BRISAY Steam Irons BRI-1 and BRI-3

The BRISAY special steam irons “Titan”, especially constructed for underpressing, provide condensate-free steam. The ironing sole is flat and high gloss polished. The high-quality materials guarantee an excellent ironing result even after many years of use.

Features of BRISAY Irons:

- Steam-heated
- Totally condensate-free
- Suitable for BRISAY special ironing tables and BRISAY pressing machines
- Particularly designed for specific use with special ironing soles.



1 Steam Iron “Titan” BRI-1

Steam iron for seam opening and removing of impressions. The iron is equipped with an accurately adjustable steam quantity control valve which is easy to set by a lever. This technique ensures a perfect closing of the steam valve. The triangular polyurethane handle makes the iron especially ergonomic.

- Weight approx. 1130 grammes (approx. 2.5 lbs.).
ironing surface 195 x 60 mm / 7.7 x 2.5 inch

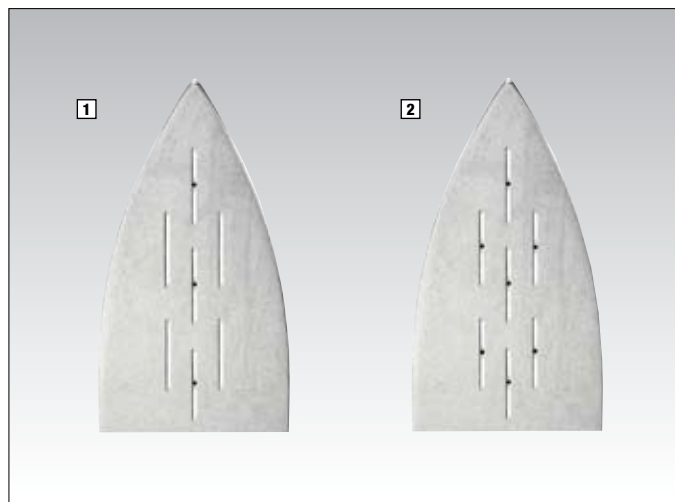

2 Steam Iron “Titan” BRI-3

Steam iron for removing of impressions. The iron is equipped with an accurately adjustable steam quantity control valve which is easy to set by a lever. This technique ensures a perfect closing of the steam valve. The triangular polyurethane handle makes the iron especially ergonomic.

- Weight approx. 1130 grammes (approx. 2.5 lbs.).
ironing surface 195 x 60 mm / 7.7 x 2.5 inch

VEIT Hand Finisher

The Hand Finisher is designed for minor corrections during final inspection, for removing wrinkles, shine and marks as well as for smoothing and freshening of garments as well as for improving the shape of all kinds of fabrics and leather. It is an indispensable aid used worldwide for finishing garments, upholstery, curtains or shoes.



VEIT Hand Finisher 2157

The VEIT Hand Finisher 2157 is an easy to manage and powerful small iron. It is indispensable for minor corrections during final inspection or for touch-up while using VEIT Multiform Finishers. Furthermore, the VEIT Hand Finisher is also suitable for a wide range of applications (see below). We recommend using the VEIT Hand Finisher in connection with our VEIT Steam Reheater 2216 which provides dry or saturated steam.

- Weight: approx. 620 grammes (approx. 1.4 lbs.)
- 100-240 Volt 600 Watt 50-60 Hz
- ironing surface: 125 x 85 mm (4.9 x 3.4 inch)

For upholstery

To freshen and remove shine and marks from napped fabrics or leather during manufacturing and in the retail sector.

In the curtain studio

To remove wrinkles caused during transport giving an excellent appearance to the curtains.

In the garment industry

For refinishing or touch-up while using Form Finishers or during final inspection. Use the Teflon frame sole for smoothing or improving the shape of uneven surfaces and prevent shine. Using the steam brush will give an excellent appearance to leather, pile or delicate fabrics.

For shoes

To remove marks and shine and to give an even appearance to velours and suede.



VEIT Varioset Ironing Tables Series

The decisive factor for an ironing station is the air flow through the garment to cool the fabric and set the ironing result. For this purpose, VEIT has developed a cover system which, together with the powerful motor, helps to provide our VEIT Varioset ironing tables with exceptional suction and blowing power. This combination ensures best ironing results even with short iron times. Naturally, the suction and blowing power is independently and electronically adjustable so that the parameters can be set to your requirements.

The working height of all Varioset ironing stations is infinitely variable so that the ironing table can be set to accommodate the height of the operator. Furthermore, you can select between different spilltrays to meet your requirements. On request, we offer further accessories, e.g. an iron gantry or a lighting assembly.

We do everything to make your work easier and more enjoyable with a high output.

Advantages:

- Especially designed cover system for an effective suction and blowing performance
- Highest quality of materials for a very long working life
- Shorter iron times due to electronic control with automatically proceeding ironing programmes
- Ergonomically designed work stations enable efficient operation



The modular Design of our VEIT Varioset Ironing Tables

The building block system of the Varioset is unique in this market. The wide range of features and bucks guarantees that you will find a Varioset unit that is ideal for your specific production and quantity requirements. Should it be necessary to change a product line, any Varioset ironing station can be readjusted to your new demands. You do not need a new ironing station – it is merely sufficient to change the buck. All these features make our Varioset an investment which pays off even after many years.



Technical Data:

Base unit Varioset:

- Dimensions: L x Wx H: 550 x 450 x 660 mm
21.6 x 17.7 x 26 inch
- Capacity : 0.55 kW
- Voltage : 400 V 50 Hz other voltages on request
- Infinitely and easily adjustable height from 755–900 mm / 29.7–35.4 inch

If you need further information about our ironing forms and surfaces, please see our brochure for ironing bucks and covers.

Varioset S+B Control System

The first ironing table with an electronically controlled operating system.

Standard veitronic control system

The temperature control for the iron is already integrated into the Varioset S+B control. This saves you from purchasing the VEIT Veitronic. The display also shows the programmed as well as the actual temperature of the iron.

Your ironing station speaks your language.

You can have any one of 5 languages displayed on the monitor (German, English, Spanish, French, Italian). You can read all messages in your language - a definite advantage if production is located abroad.



Servicing intervals displayed

Your Varioset will record the running times of your blower motor and remind you automatically that cleaning and servicing of your units is due. The regular cleaning and servicing of the fan impeller and covers guarantees a consistently good ironing result as well as a long working life.

Service information programme

In case of malfunctions, of which occurrences are extremely rare, the ironing station will retain information about the defective component on its display, thus facilitating troubleshooting for servicing engineers. An important diagnostic tool that saves you time and money.

Standard ironing programme memory

Ironing quality is determined by carefully maintaining precise steaming and suction time parameters. You can programme your Varioset with any ironing sequence you might need at some later time; the ironing station will repeat this sequence exactly and automatically. A constant quality and productivity is therefore guaranteed.



VEIT Varioset Seam Ironing Stations

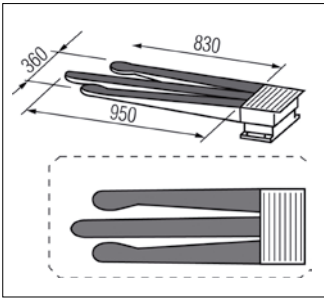

For processing of:

- Jackets
- Men's blazers

For underpressing



VEIT Varioset Jacket Seam Ironing Station

This special-purpose ironing station has been designed for opening seams along the backs, sides and shoulders of any type of jacket. With its special triple buck complemented by the shoulder seam attachment five seams are ironed at one time with less folding effort. The timer automatically repeats the required ironing program and guarantees a constant high-quality ironing result with short ironing times.

- Picture: base unit S+B with suction and blowing function, support stand, double kickerplate, air-vent chimney with display, iron rest, triple buck jacket seam 950/830 x 360 mm / 37.4/32.68 x 14.17 inch with prefit cover, point right, shoulder seam assembly (also available without shoulder seam assembly or with point left)

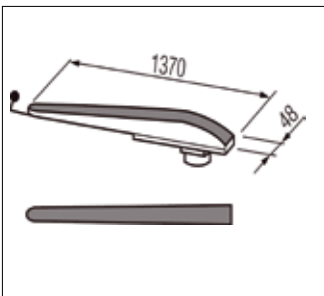

For processing of:

- Trousers

For underpressing



VEIT Varioset Trouser Seam Ironing Station Standard

The special ironing buck, which is mounted on the standard base module, guarantees easy opening of the crotch and the side seams and optimum hip ironing. The hip area can be ironed without problems due to the special shape of the buck. The standard trouser seam ironing station standard is available with a ladies trouser seam buck shape or a men's trouser seam buck shape – it is also available with a Timer unit as an option.

- Picture: standard base unit with suction, support stand, single kickerplate, air-vent grill, trouser seam buck men's wear with heating 1370 x 48 mm / 53.94 x 1.89 inch with prefit cover, point right, spill-tray with leg support, iron rest.

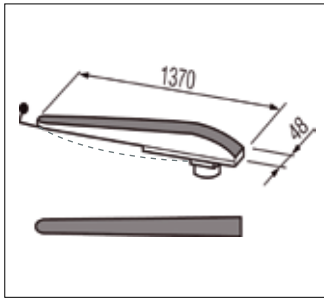

For processing of:
• Trousers
For underpressing



VEIT Varioset Trousers Seam Ironing Station with chain

The trouser seam ironing buck is completed with a chain tensioning system. The trouser seam is positioned correctly and there is no overstretching by the chain thus avoiding wrinkles. The ironing result is therefore better compared to the trouser seam buck standard. The trouser is held in place by the tensioning system therefore the operator's hands are free for ironing. The crotch seam and side seams of single legs as well as complete trousers can be opened in a minimum amount of time. The trouser seam ironing station with chain is available with a ladies trouser seam opening buck shape or a men's trouser seam opening buck shape.

- Picture: base module standard with suction, support stand, separated kickerplate, air-vent grill, trouser seam buck ladies' wear with heating and chain 1370 x 48 mm / 53.94 x 1.89 inch with prefitt cover, point right, Timer VEIT 7934, spilltray with leg support, iron rest.

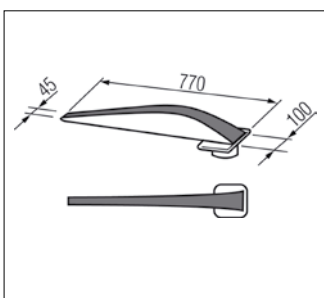

For processing of:
• Jackets
• Men's blazers
• Coats
For underpressing



VEIT Varioset Sleeve Seam Ironing Station

The sleeve seam buck guarantees an easy and perfect opening of sleeve seams of jackets, men's blazers and coats. The sleeve seam buck includes an iron rest as a standard feature.

- Picture: base module standard with suction, support stand, single kickerplate, air-vent grill, sleeve buck special 770 x 45/100 mm / 30.31 x 1.77/3.94 inch with prefitt cover and iron rest, point left, spilltray with leg support.

VEIT Varioset Dress Board and All-Purpose Ironing Tables

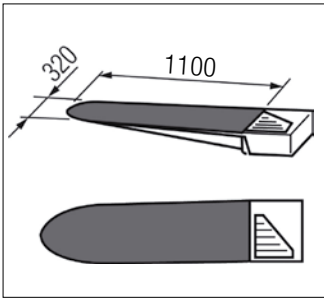

For processing of:

- Skirts
- Dresses
- Blouses
- Jackets
- Coats

For finishing



VEIT Varioset Dress Board Ironing Tables

are available, as required, pointing left or right. They can be equipped with various shapes and sizes of ironing surfaces and are ideal for the ironing of skirts, dresses, jackets, blouses. A swivelarm assembly designed for a large variety of ironing bucks as well as a support gantry and a lighting system make this station a perfect ironing unit for processing of ladies' wear. All dress board ironing stations can also be assembled pointing right.

- Picture: base module S+B with suction and blowing, support stand, double kickerplate, air-vent chimney with display, spilltray, ironing surface dress board narrow 320 x 1100 mm / 12.6 x 43.31 inch, point left, iron rest, industry soft cover, swivelarm assembly with sleeve buck medium with cover, lighting assembly.

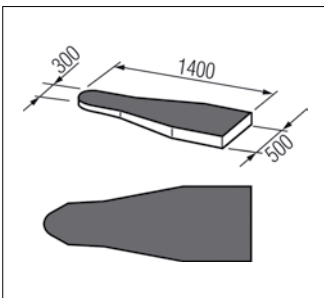

For processing of:

- Trousers
- Skirts
- Dresses
- Blouses
- Jackets
- Coats

For finishing



VEIT Varioset CR2

An all-purpose ironing station offering a wide range of bucks. With its custom designed ironing surface, trousers, dresses, skirts, coats, blouses, jackets and other garments can be processed most efficiently. This ironing station is a perfect solution for those who need as much flexibility as possible such as studios, tailors, returns departments, refinishers and textile care companies.

- Picture: base module S+B with suction and blowing, support stand, double kickerplate, air-vent chimney with display, ironing surface CR2 300/500 x 1400 mm / 11.81/19.69 x 55.12 inch, point right, iron rest, industry soft cover, swivelarm assembly with sleeve buck medium with cover, lighting assembly.

VEIT Varioset Flat Top and Finishing Ironing Stations

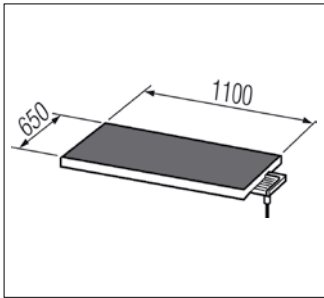

For processing of:

- Trousers

For finishing

- almost all garments

for underpressing if no special ironing tables are available



VEIT Varioset Flat Top Ironing Tables

Fitted with a suction and blowing unit, this unit can be used to finish trousers. This all-purpose ironing station can be fitted with smaller or larger ironing surfaces. A great advantage of this ironing table is its universal use.

- Picture: base module S+B with suction and blowing, support stand, double kickerplate, air-vent chimney with display, iron rest, ironing surface 1300 x 650 mm / 51.18 x 25.59 inch with industry soft cover, 2 swivelarm assemblies with sleeve buck medium and egg-shaped buck with covers, lighting assembly and iron gantry (without cover).

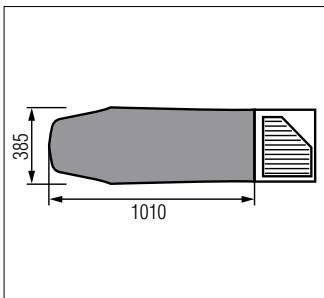

For treatment of:

- Blouses
- Shirts

For finishing



VEIT Varioset Blouse and Shirt Ironing Station

On this special rectangular ironing buck featuring rounded edges, blouses and shirts can be perfectly positioned for excellent finishing results with minimal lay-out and handling times. Depending upon the particular application, round or pointed surfaces are available for this blouse ironing station. The ironing surface has been developed to fit the form of a shirt or blouse so that a complete front part can be ironed with only one working step. This saves time and minimizes the lay-out and handling times compared to the dress board ironing table.

- Picture: base module S+B with suction and blowing, support stand, double kickerplate, air-vent chimney with display, spilltray, ironing surface for blouses and shirts 1010 x 385 mm / 39.76 x 15.16 inch-with industry soft cover, point left, iron rest, swivelarm assembly with sleeve buck medium with cover.

VEIT Varioset Finishing Ironing Station

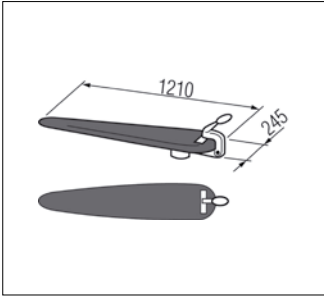

For processing of:

- Men's trousers

For finishing



VEIT Varioset Trouser Leg Ironing Station

This table is particularly suitable for removing imperfections in seam and/or waistband areas. For this purpose, we recommend using this trouser ironing station and its all-purpose buck. A waistband clamp is standard and will keep trousers in place while the blowing function is being used. The trouser leg ironing station gives your trousers the finishing touch and guarantees excellent finishing quality in the waistband and lateral seam areas.

- Picture: base module S+B with suction and blowing, support stand, double kickerplate, air-vent chimney with display, spilltray, universal ironing buck trouser leg with clamp 1210 x 245 mm / 47.64 x 9.65 inch with industry soft cover, iron rest.

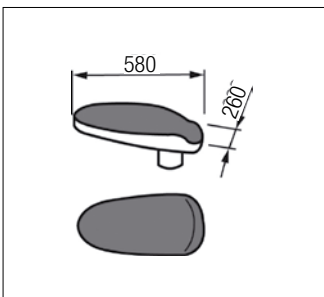

For processing of:

- Hip area of trousers



VEIT Varioset Hip-Bow Ironing station

This table has been especially designed for finishing of hip-bow. The ironing result is a hip-bow without marks.

- Picture: base module S+B with suction and blowing, support stand, double kickerplate, air-vent chimney with display, spilltray, ironing buck hip-bow with industry soft cover, iron rest.

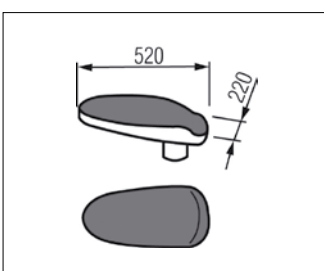

Also available as buck for ladies' wear

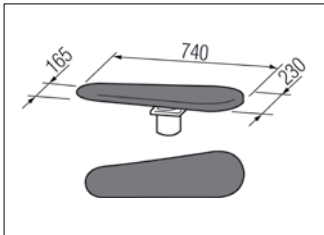

For processing of:

- Sports jackets
- Blazers
- Jackets
- Costumes

For finishing

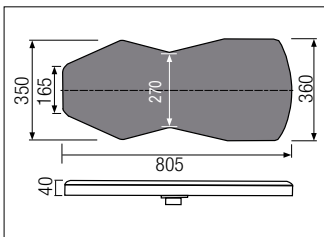

Also available as buck for ladies' wear

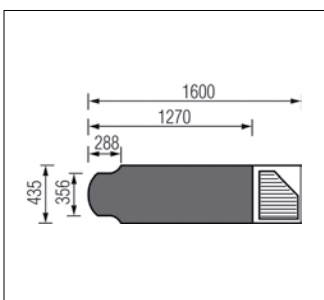

For processing of:

- Coats

For finishing



VEIT Varioset Finishing Station for men's and boy's wear and ladies' outerwear

The finishing station is particularly suitable for processing all sorts of jackets, blazers, suits etc. Various bucks (such as the all-purpose one shown) for suits etc. can be mounted on a specially designed spilltray for a crease-free storage of the garment. The ideal finishing station to meet your requirements can be assembled easily and quickly.

- Picture: base module S+B with suction and blowing, sound absorber, display, short support stand, double kickerplate, finish spilltray, universal buck long 740 x 230/165 mm / 29.13 x 9 x 6.5 inch with industry soft cover, iron rest.



VEIT Varioset Coat Finishing Station

This station has been designed specially for long and wide garments such as coats. The station includes an extended spilltray for long garments and an extra large ironing buck shape for coats. This special ironing buck allows the ironing of large parts in a minimum amount of time. Depending upon requirements, a swivelarm, which is standard equipment, can be fitted with any one of a large variety of VEIT bucks to meet your needs.

- Picture: base module S+B suction and blowing, support stand, double kickerplate, air-vent chimney with display, spilltray, ironing buck for coats 1200 x 435 mm / 47.24 x 17.13 inch with industry soft cover, iron rest, point right, swivelarm assembly with sleeve buck medium and cover.

VEIT Varioset Lining Finishing Station

Linings are pressed with the blowing function on an air cushion so as not to destroy the finish of the upper material when pressing the lining inside pockets. An additional attachment supporting various bucks facilitates the ironing of difficult areas with various types of jackets. Together with a dry iron, an optimised spraying unit creating a very fine mist makes it possible to remove the most difficult creases and wrinkles from highly sensitive lining fabrics.

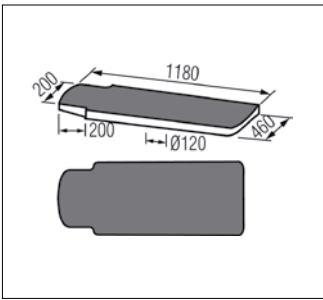

For processing of:

- Sports Jackets
- Blazers

For finishing



VEIT Varioset Lining Ironing Station Concave

The concave ironing surface maintains the pressed shape of the garment from the previous pressing operations. Moreover, this buck guarantees ideal positioning of the armhole area. For shoulder ironing, we recommend using the shoulder seam attachment and an appropriately shaped buck.

- Picture: base module S+B with suction and blowing, sound absorber, display, short support stand, double kickerplate, finish spilltray, lining ironing buck concave 1180 x 200/400 mm / 46.46 x 7.87/15.75 inch with soft cover, iron rest.

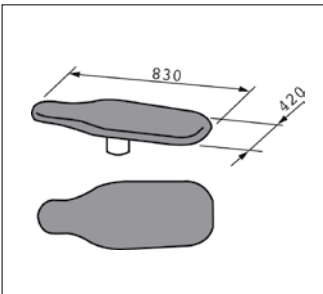

For processing of:

- Ladies' blazers
- Ladies' jackets

For finishing



VEIT Varioset Lining Ironing Station Convex

Due to its slightly convex surface, the iron will not touch shell fabrics when the trim or facing are finished. This buck shape also allows shoulders to be processed optimally even without a special-purpose shoulder buck. All lining ironing surfaces can be rotated by 180° so that their tips may point left or right.

- Picture: base module S+B suction and blowing, sound absorber, display, short support stand, kickerplate, finish spilltray, lining ironing buck convex 830 x 420 mm / 32.68 x 16.54 inch with soft cover, iron rest, shoulder seam assembly.

Uniset Ironing Tables

We have designed our VEIT Uniset ironing tables for all our customers who demand the excellent suction and blowing power of our ironing tables but do not require the advanced features of our Varioset ironing tables. Our wide variety of ironing bucks and accessories such as iron gantries or lighting assemblies are also available for our Uniset ironing tables making your work easier and more effective.

Features Uniset

- Base module with kickerplate, iron rest and standard cover
- Height adjustment from 720-950 mm / 28.35 x 37.4 inch
- Voltage 230 V, 50 Hz, motor capacity 0.55 kW
- Weight approx. 75 kg (165.20 lbs)
- Wide variety of ironing bucks and covers

Optional equipment:

- Iron gantries, lighting assemblies for iron gantries, shelves, swivel bows, extension for air-vent chimney.



VEIT Uniset 4235 Dress Board S (Suction) TURBO

is especially suitable for ironing ladies' wear such as dresses, skirts and blouses. Integrated wheels allow it to be quickly moved to another location without much effort. The table is equipped with a cloth-covered spilltray frame for holding garments.

- Picture: base module S with suction unit and kickerplate, sound absorber, spilltray frame with cloth, ironing buck dress board narrow 1100 x 320 mm / 43.31 x 12.6 inch with standard cover, swivelarm assembly with sleeve buck medium incl. cover, iron rest.

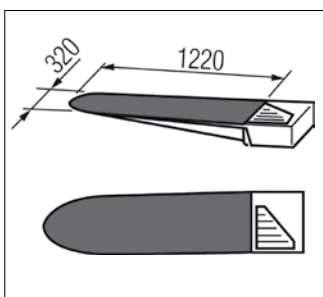

For processing of:

- Skirts
- Dresses
- Blouses
- Jackets
- Coats

For finishing



VEIT Uniset 4255 Dress Board S+B (Suction and Blowing)

is designed for finishing garments. The blowing function offers facilitates cost effective ironing of face fabrics and linings, in various sizes and materials, without leaving pressure marks. The iron gantry with lighting assembly and air-vent chimney makes your work more convenient.

- Picture: base module S+B with suction and blowing unit with kickerplate, air-vent chimney, cloth-covered spilltray frame, ironing buck dress board narrow 1100 x 320 mm / 43.31 x 12.6 inch with standard cover, swivelarm assembly with sleeve buck medium incl. cover, iron rest, iron gantry.

Uniset Ironing Tables

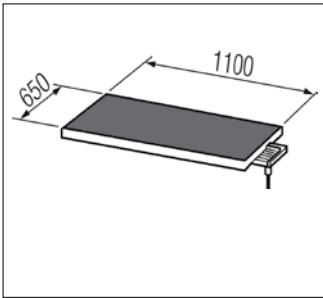

For processing of:

- Almost all garments

For underpressing if no special ironing tables are available



VEIT Uniset 4435 Flat Top S (Suction) TURBO

is designed for the garment industry, studios and alteration shops. The flat top is very suitable for underpressing seams, linings and for ironing small parts such as collars, cuffs, pockets and also for applying pads.

- Picture: base module S with suction unit and kickerplate, sound absorber, ironing surface 1300 x 650 mm / 51.18 x 23.62 inch with standard cover, 2 swivelarm assemblies with sleeve buck medium and egg-shaped buck small incl. covers, iron rest, iron gantry.

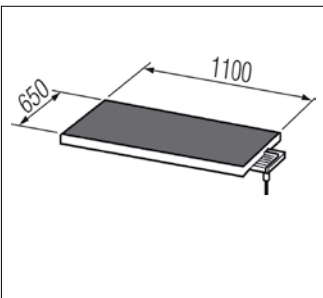

For processing of:

- Trousers

For Finishing

- Almost all garments

For underpressing if no special ironing tables are available



VEIT Uniset 4455 Flat Top S+B (Suction and Blowing)

For underpressing and finishing, as above, with the addition of suction and blowing unit for finishing of trousers to avoid shine and impressions on sensitive fabrics.

- Picture: base module S+B with suction and blowing unit and kick-plate, air-vent chimney, ironing surface 1300 x 650 mm / 51.18 x 23.62 inch with standard cover, 2 swivelarm assemblies with sleeve buck medium and egg-shaped buck small incl. covers, iron rest, iron gantry with lighting assembly.

VEIT Upsteam Table 7506

VEIT Upsteam Table 7506

The steam heated aluminium working surface of the VEIT upsteam table allows ironing of large pieces or two smaller parts. It completely guarantees even steam distribution and suctioning over the entire surface. All parts in contact with steam are made of rust-proof materials. This will prevent spots on the garments, guarantee long working life and trouble-free operation. The quiet, high-capacity impeller enables excellent setting of the shape with short and efficient processing times. The VEIT 7506 is operated manually by double pedals or automatically via a timer control. The inclination of the table surface is adjustable (6°, 9°, 12°).



The timer control is standard. The times for steaming, shaping and suction are precisely programmable and can be selected automatically. This allows easy operation to produce an even finish.

- Steam-heated working surface 1800 x 900 mm / 70.87 x 35.43 inch, timer control, double foot pedals and inclination of surface (6°, 9°, 12°)

Options

- Connection unit with steam drier
- Iron rest with mounting

Accessories

- Velcro tape set (2 pieces)
- Glove

VEIT Curtain Ironing Table 7617

VEIT Curtain Ironing Table 7617

with an ironing surface of 3000 x 700 mm / 118.11 x 27.56 inch is available with or without steam line with condensate return. The iron can be suspended on the iron gantry. This avoids scorching the garment or the cover. The operator can handle the iron with little effort for easy working, quick finishing and best ironing results.



Iron gantry

The standard iron gantry with balancer and swivel bow enables the user to move the iron easily in all directions and avoids scorching the curtain and the table cover.

Transport unit

The optional transport unit assures automatic and tensionless transport of the curtains improving the performance and the quality.

Steam line

The steam line with condensate drain guarantees excellent steam quality without condensate.

Equipment

- Kickerplate for easy use of suction
- Iron rest for safe deposit of iron
- Strong suction across the entire surface area
- Reduced noise for pleasant working conditions
- Ergonomic height adjustment

VEIT Ironing Soles

Iron soles allow an optimal adjustment of the iron to the respective garment. The teflon coating prevents shine and helps the iron to glide smoothly. Evenly spaced holes ensure a constant flow of steam. With the safety sole and the various frame piles, the steam quality can be adapted according to your needs.

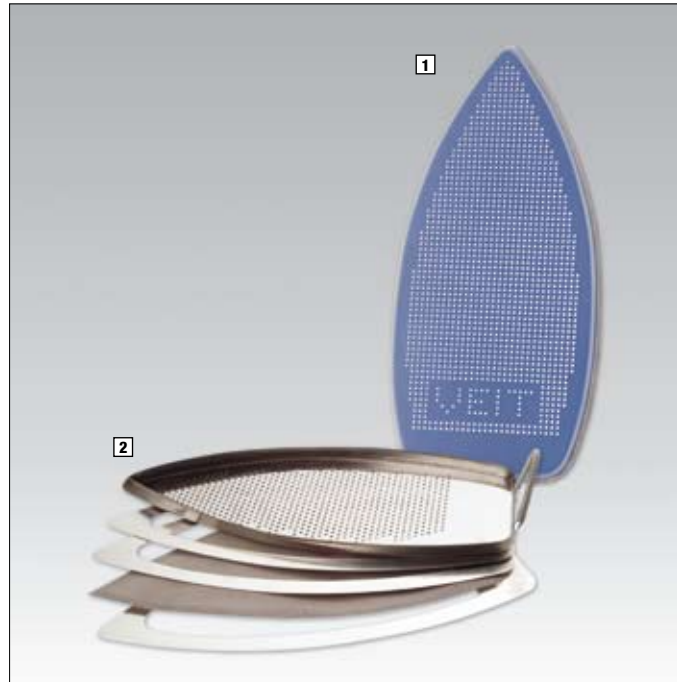

1 VEIT Metal Frame Sole

The solid aluminium framed sole gives a snug fit. The teflon frame sole reduces the surface temperature by approx. 40°C.

Available for:

- VEIT HP 2003
- VEIT HS 2003
- VEIT UNIMAT 2128

2 VEIT Safety Sole

The safety sole using the steam chamber principle is made of stainless steel. Various frame plies improve the steam quality and regulate the contact temperature. The additional wire mesh ensures the very soft spread of steam.



Teflon Frame Sole and Brush for VEIT Hand Finisher 2157

Standard equipment includes layers of aerofitt and stainless steel to provide micro fine steam. The teflon frame sole removes creases without shine marks on flat materials. The brush is used for napped and sensitive fabrics.

- With layers
- Brush hard
- Brush soft

BRISAY Ironing Soles

All-purpose contour ironing sole with edge suction

Application area: seam ironing and seam opening of very steam sensitive fabrics



Contour ironing sole for BRI-1

Application area: opening of trouser leg seams (for machine types: BRI-184/101, BRI-188/101)



Contour ironing sole for BRI-1

Application area: opening of trouser leg seams (for machine types: BRI-184/101, BRI-188/101)

Contour ironing sole for BRI-1

Application area: polish of sleeve head (machine type: BRI-166/101)

Cleaning Agents

Cleaning agents for heavily soiled iron soleplates

The ironing result depends on the condition of the iron. Therefore, VEIT offers a wide range of accessories and cleaning agents, which readily meet all modern requirements. Although designed for VEIT irons, these accessories are suitable for any other make.

1 VEIT Fitspray

Cleaning agent for light soiling. For application on the hot iron sole as well as on teflon or frame soles. VEIT Fitspray makes a clean and antistatic sole to glide smoothly over the garment. Spray can 330 g



2 VEIT Cleaner

Cleaning agent for normally soiled iron soleplates. For application on hot iron sole. After a short time, rub with a soft cloth.

- Cleaner stick, 100 x 20 mm / 4 x 0.72 inch, 10 pieces

3 VEIT Abrasive Cleaning Stone

Cleaning agent for normally soiled or heavily soiled iron soles. Clean cold iron sole with VEIT abrasive cleaning stone, water and soap.

- VEIT Abrasive Cleaning Stone 80 x 50 x 20 mm / 3.15 x 1.97 x 0.79 inch, 1 piece

4 VEIT Soleplate pad

Cleaning agent for heavily soiled iron soles. For application on cold iron sole.

- VEIT Soleplate pad, steel-wool, 10 pieces

Accessories

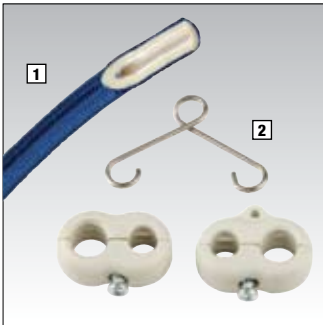

2 Hose Clamps Set
for combining of cables and hoses with a diameter of 8-12 mm / 0.31-0.47 inch and for connecting the device to hang hose and cable supports.

- For diameter 8-12 mm / 0.31-0.47 inch, consisting of:
6 standard clamps
4 clamps with eyelet
2 suspension hooks

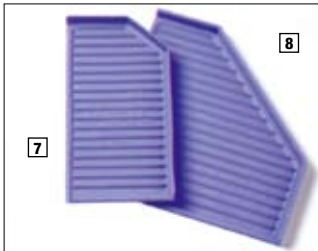

7 + 8 Iron Rests
are made of heat resistant silicone to protect the iron sole from damage and to protect table from excess heat.
7 silicone plate standard 140 x 285 mm / 5.51 x 11.22 inch
8 silicone plate large 260x 290 mm / 10.24 x 11.42 inch
Without picture: silicone glue for iron rests 90 g tube

1 High-Pressure Steam Hoses

High quality steam hoses available as a replacement for VEIT irons, but also suitable for other makes of iron. The high-pressure hose for HP irons provides improved steam quality as the condensate is reduced due to teflon core inside the hose and strong silicone insulation outside.
High-pressure hose for VEIT HP 2003 (running meter)

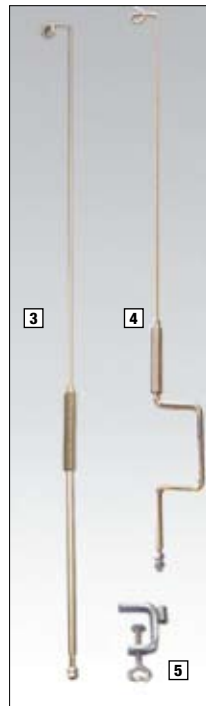

3 – 5 Hose and Cable Supports

To suspend cable and steam hose at the work station or to fasten the Veitronic control unit.

- 3** hose and cable support straight with thread M8, length 1000 mm / 39.37 inch
- 4** hose and cable support with gap for Veitronic with thread M8, length 1000 mm / 39.37 inch
- 5** clamp for hose and cable support for universal mounting of hose and cable support with thread M8



9 Heat Protection

for insulation of steam hoses in the working area. It protects the operator from burns and prevents build-up of unnecessary heat.
Length 650 mm / 25.59 inch

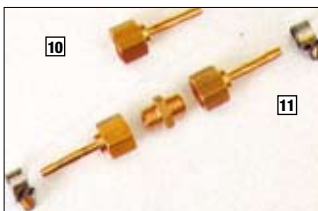

10 + 11 Hose Couplings

made of brass for high-pressure hoses to connect steam sources or for extension purposes.
10 hose nozzle 3/8" diameter 5-6 mm / 0.2 x 0.24 inch for connection of steam generators
11 hose coupling diameter inch 5-6 mm / 0.2 x 0.24 inch for extension purposes

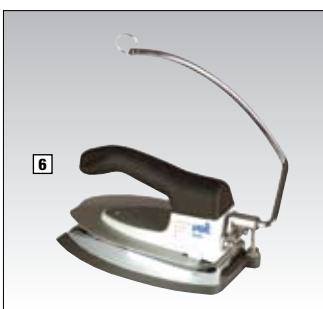

6 Swivel Bow
for HP 2003 iron – for tables with iron gantry
• Dimensions: approx. 220 x 120 mm / 8.66 x 4.72 inch



12 VEIT Anti-Shine Spray

This completely natural product removes even the most extreme shine from almost all material. Simply spray the fluid onto the fabric, wait for a few seconds and remove the fluid with steam.

- Small unit: 2 bottles Anti-Shine Spray 250 ml (15 cubic inches), 1 spray bottle
- Large unit: 1 bottle Anti-Shine Spray 1000 ml (60 cubic inches), 2 spray bottles
- Anti-Shine-Spray 5 bottles 1000 ml (60 cubic inches)

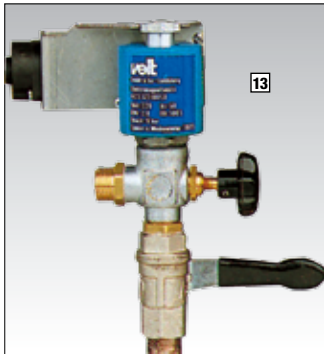

13 Steam Connection Unit VEIT Steam Adapter 2215

A control unit for high-pressure steam consumers such as high-pressure irons, steam sprayers, spotting pistols, seam irons etc. The solenoid valve is activated by the micro switch or contactor at the steam unit. Recommended for a condensate-free steam line.

- for max. 5 bar (73 psi), to be soldered into steam line ½"



14 Steam Connection Unit VEIT Eco Steam Adapter 2215

Like VEIT Steam Adapter 2215 but without connection cable, T-piece and ball valve.



15 VEIT Condensor 2210

This connection unit is designed for existing central steam supplies. The condenser discharges condensate, which is built up inside the line, and with its large heat insulated steam chamber, provides the best condensate-free steam quality. 230 V

- dimensions: LxWxH: 125 x 80 x 250 mm / 4.92 x 3.15 x 9.84 inch different versions are available:
- for connection to central condensate line with condensate trap
- with connection unit including condensate trap
- with support stand and condensate trap



16 Support Stand

The support stand guarantees the proper function of the VEIT Condensor 2210 as it is automatically mounted in the right position. It includes condensate discharge and dirt trap

- Dimensions: LxWxH: 290 x 290 x 690 mm / 11.42 x 11.42 x 27.17 inch
- Support stand is available with:
- condensate trap
 - with VEIT Condensor 2210



17 VEIT Steam Reheater 2216

Working with a mobile VEIT steam generator, the VEIT 2216 Steam Reheater provides an excellent steam supply for the VEIT Hand Finisher 2157. The completely adjustable heating cycle creates good quality condensate-free steam.

- 230 V, 800 W
- Dimensions: LxWxH: 170 x 130 x 330 mm / 6.69 x 5.12 x 12.99 inch

18 Swivel Holder for VEIT Steam Generators

Together with a VEIT steam generator it is the ideal combination as a support for the VEIT steam reheater 2216 and as a resting place for the VEIT Hand Finisher 2157.

- Dimensions: Height: approx. 833 mm (32.68 inch)



19 Telescopic Holder with Support Stand

Stand serves as an ergonomic support for the VEIT Hand Finisher 2157. It is fully adjustable and can therefore be easily positioned to meet the requirements of the operator.

- Dimensions: LxWxH: 290 x 290 x 1200-1900 mm / 11.42 x 11.42 x 47.24-74.80 inch

Pressing for Excellence – Why you can put your trust in the VEIT-Group

For over 50 years, the requirements and the problems of our customers world-wide have been our most important challenge. For decades, world-famous brands in the German and the international garments industry have had confidence in the innovative, high-quality products and services of the VEIT-Group.



Our experts consult with you as a partner to assist you in finding the best solution for your project no matter if you are planning to use individual machines or if you need a complete production line.



Prompt delivery and professional installation of your machines and systems goes hand in hand with premium training with which we enable your staff to achieve the highest possible productivity.

Worldwide 24 hr Service Hotline

Our service technicians worldwide are available around the clock so that your production works with as little disruption as possible.



We look forward to dealing with you personally!

Your local sales agent:

VEIT GmbH

Justus-von-Liebig-Str. 15
D-86899 Landsberg/Lech
Germany
Tel. +49 (8191) 479-204
Fax +49 (8191) 479-199
E-Mail: info@veit.de
www.veit-group.com

BRISAY-Maschinen GmbH

Mittelweg 4
D-63762 Grossostheim-Ringheim
Germany
Tel. +49 (6026) 997-0
Fax +49 (6026) 997-100
E-Mail: info@BRISAY.de
www.BRISAY.com

KANNEGIESSER Garment & Textile Technologies GmbH & Co.

Valdorfer Strasse 100
D-32602 Vlotho · Germany
Tel. +49 (5733) 87 13-0
Fax +49 (5733) 87 13-45
E-Mail: info@veit-kannegiesser.de
www.veit-kannegiesser.com

