

Fusing Machines



VEIT KANNEGIESSER Fusing Machines

VEIT KANNEGIESSER has developed the best technology for effective and reliable fusing. Our long lasting quality is no coincidence. [We offer technology for an ideal finishing result.](#)

What is important to consider?

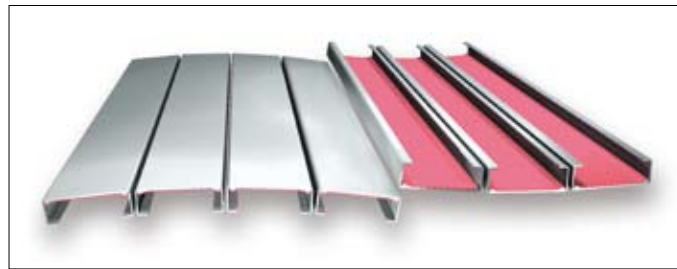
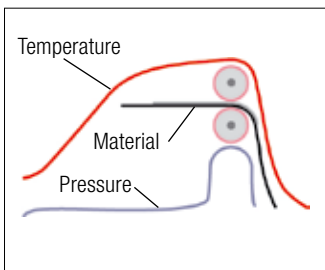

The pressure system

Applying the correct pressure is a key ingredient of the fusing process. It is a known fact that the exact pressure, and the corresponding inner connection between face fabric and interlining, are vital to guarantee an optimal transfer of the glue. The VEIT KANNEGIESSER pressure system ensures an accurate connection between face fabric and interlining allowing an even spreading of the glue.

The heating system

The temperatures must be kept constant, with minimal fluctuations throughout the day. VEIT KANNEGIESSER offers a patented and unique heating system with the following advantages:

- a heating element, which transfers the temperature evenly over the whole surface with minimal heat loss.
- Arched heating zones to guarantee an optimal inner heat transfer from the heating element via the conveyor belt to the material being fused.
- Thermostats adjust themselves to constantly changing temperature conditions sensitively, quickly and without fluctuations.



The transport system

The VEIT KANNEGIESSER conveyor belt has the following characteristics:

- Stability, tensile and breaking strength
- Flat surface to avoid impressions on sensitive face fabrics
- Free of pores so that no glue can deposit on face fabrics
- Temperature stability (above 200°C)
- Adhesive resistant coating
- Antistatic belt to avoid displacements

Touch screen control

The touch screen control allows the adjustment and control of all required parameters:

- Indication of set/actual temperatures of the different heating zones
- Indication of fusing time, speed and pressure
- Filling level indicator for the optionally available stacker
- Creating and storing of fusing programs
- Self-diagnostic function

MultiStar DX – Fusing on a Grand Scale

The machine series MultiStar DX with its modular system is designed to satisfy the individual demands of our customers. Every production line is unique, therefore, our fusing machines can always be individually configured.

The MultiStar DX series is characterised by:

- Two separately and sensitively controlled surface contact heating zones which allow the heating direction to be adjusted according to the material
- A user-friendly touch screen with a self-diagnostic function
- Three different pressure systems which can be changed at any time.
- The basic machine can be equipped with entry feed systems and stackers to form a production line.
- The machines are maintenance and service friendly



MultiStar DX 1000 + T

The machine, equipped with a feeding table, is particularly suited for fusing small to middle-sized pieces or for fusing of shirts. The loading side offers climatically pleasant work surroundings due to the short lower conveyor belt. The feeding table can be changed to the optional feeding system FE.



MultiStar DX 1400 + FE

This machine is equipped with the feeding system FE. The entry belt can be switched on and off at any time using the foot switch. This is particularly useful for materials which are difficult to lay. The transition from the entry belt to the conveyor belt of the machine occurs shift-free and is directly synchronised with the second belt.

MultiStar DX – The Pressure System

VEIT-KANNEGIESSER offers different pressure systems to fulfil the individual requirements of every material combination. The pressure systems can be changed at any time.

FLEXO Double Pressure System DX-CFC

The combination of FLEXO and standard pressure systems was used to develop a new type of double pressure system for processing the complete range of new outer fabrics. Embedding the face fabric into the air-filled FLEXO pressure system is a unique and patented procedure. Especially designed for outerwear, thick or fine fabrics can be fused with the same pressure. This pressure system has proven to be very effective even on sensitive fabrics, which are hard to fuse because of their surface structure or their

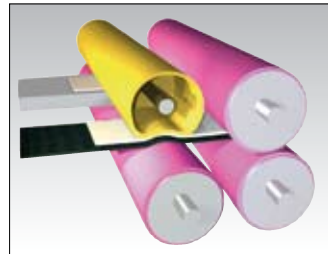

composition. For the first time even these fabrics can be treated without problems. The surface of the FLEXO hose can build up constant pressure without any peaks, thus eliminating the effects that normally lead to flattening, glazing or change of colour. Both pressure systems can be individually adjusted within this combination, providing the ideal solution.

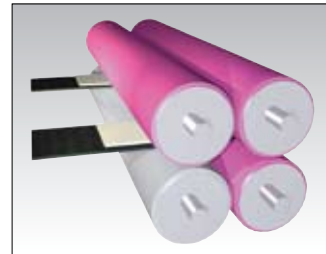

Double Pressure System DX-CU

The universal double pressure system has proven particularly suitable for face fabrics and interlinings, which are hard to fuse. The first pair of pressure shafts are constructed to produce a high line pressure, which is needed for fusing of shirts, and for high twisted fabrics of outerwear. Excellent co-efficiency of adhesion can be achieved, which has a large influence on wash-resistance levels. The second pressure system spreads pressure over a larger area, which leads to a perfect distribution of the glue and is therefore ideal for sensitive garments. Both pressure systems can be adjusted individually or synchronised, which enables different pressure combinations and is ideal for glues with 'jump-back' potential.

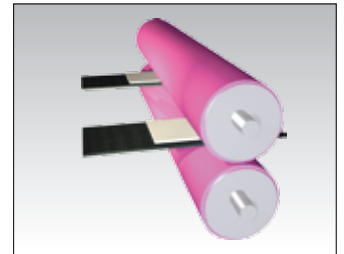

Standard Pressure System DX-C

This pressure system is created for a broad product range of fashionable face-fabrics and corresponding interlinings. The pneumatic pressure shafts are equipped with a special silicone coating and fulfil the highest demands. This system guarantees trouble-free fusing of lightweight and medium face fabrics.

MultiStar DX – The Heating Systems

Individually adjustable temperatures for face fabrics and interlining are a decisive factor so that all material combinations can be processed.

VEIT KANNEGIESSER offers a patented heating system with the following advantages:

- Patented heating element, which transfers the temperature evenly over the whole surface with minimal heat loss.
- Arched heating zones guarantee optimal inner heat transfer from the heating element via the conveyor belt to the material being fused.
- Two heating zones, where the temperature can be adjusted separately.
- The arrangement of the heating zones can be changed at a later date.
- No large gap between the individual heating elements. This prevents any cooling down of the glue in the heating area and avoids negative influences on grip and adhesion.
- Temperature control which guarantees uniformity between adjusted and actual temperature. This is done through a sensor that is located directly on the heating mat.
- Thermostats adjust themselves to constantly changing temperature conditions sensitively, quickly and without fluctuations.

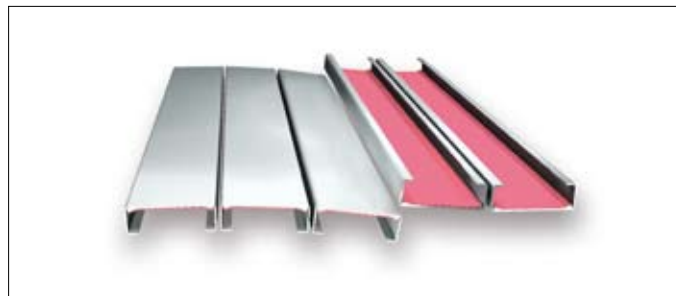

Heat Zone 2/3

The classic arrangement of the heating elements for shirts and casuals on fusing machines DX 1000 and 1400, where the glue is melted by the first upper heating zone and then soaked into the fabric throughout the longer lower heating zone.

Heat Zone 3/2

Excellent results can be achieved with this arrangement of heating elements on fusing machines DX 1000 and 1400. This configuration is mainly suited for fabrics and interlinings of outerwear. The face fabric is gently heated up by the lower heating zone without fabric shrinkage. Generally, more voluminous outerwear reacts positively to this configuration of the heating elements.

Heat Zone 3/4

The extended heating zone serves primarily for larger production lines and their need for constant temperature over the whole surface of the machine, and for full coverage of very thick fabrics.

Heat Zone 4/3

This arrangement of heating zones is frequently used during sandwich fusing of outerwear. The lower entry area, which is controlled by two thermostats produces an ideal temperature inside the machine so that both face fabrics can be evenly and gently heated up for sandwich fusing. This prevents shrinkage of the fabric and at the same time gives good adhesion results. This heating arrangement is also preferred for applications outside the garment industry, for example, for fusing of leather and synthetic materials.

MultiStar DX – Options

The Return Feed System

The working width of the 1000 mm MultiStar DX models can be equipped with a return feed system. This is especially suitable for small production, with a maximum of two operators, where a stacker would not be economical.



Lateral Loading Tables

For easy feeding of the fusing machines with articles of different width, all MultiStar DX models can be equipped with variable lateral loading tables.



Waistband Fusing Device

The winding and unwinding device for waistbands allows economic and continuous fusing of trouser and skirt waistbands or belts. A waistband guide with adjustable width enables precise positioning of the fabrics.

This option is also available for other fusing machines.



From a Fusing Machine to a Fusing Production Line

Reduce your required space with the right fusing production line. We offer modular systems of ergonomical, adaptable preparation areas for face fabric and interlining cuttings. These can be adapted to every form of work organisation.



Advantages of a professional workplace organisation

- Elimination of setting-up and secondary processing time
- Creation of production islands with appropriately designed and transparent operating cycles
- Well-defined and quick classification of different versions of interlinings and face fabrics.
- Accelerated and correct positioning of sensitive, elastic and super light-weight face fabrics

Feeding System FE-L

Benefit from the advantages of the flexible workplace organisation FE-L

Efficient utilisation of your fusing machine can be guaranteed by installing this extended 3 metre feeding system. Using the extended working area, an average of 8 operators can load the fusing machine. To avoid any movement of the fabrics during changeover from the feeding belt to the transport belt, the FE-L is perfectly synchronised with an electrical interlock to the automatic control system of the fusing machine.



Other fusing machines can also be easily equipped with this extended feeding system. The belt speed can be controlled manually with a potentiometer. If the extended feeding system is connected to a VEIT KANNEGIESSER fusing machine, the belt speed is controlled automatically. The FE-L can be optionally equipped with a maximum of four lateral loading tables (width: 220 mm). This extends the feeding area for face fabrics and interlining cuttings.

Main advantages

- On average 8 operators can load the fusing machine
- Efficient utilisation of your fusing machine
- The feeding belt can easily be switched on or off by pressing a foot switch. This will avoid problems caused by displacement of interlinings with fabrics which are difficult to load

ET - Input Batch Conveyor

Principle

Each operator is allocated to a synchronised loading belt. The non-continuous conveyor allows exact positioning of the parts. After activating a contact bar, the workstation conveyor transports the parts forward at high speed to a transfer belt and stops again, all in the time it takes the operator to pick up the next part. The loading station can be equipped with work aids, for example loading tables, to increase comfort and productivity.

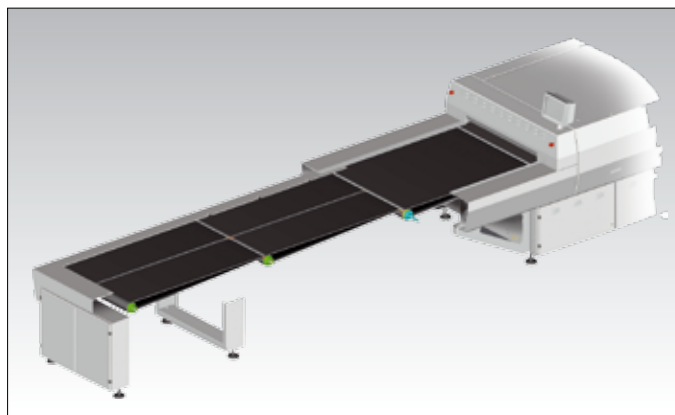

Advantages

- Elimination of the time for the additional handling needed to push the part from the worktable onto the moving fusing machine conveyor belt. Overall handling time is reduced by 10-20 %.
- Unstable and elastic parts, or parts pre-cut for darts or pockets – all usually subject to shifting problems – can be loaded with no displacement.
- Better machine utilisation and shorter processing times bring cost savings.

Design

The loading belt must operate at high speed in order to complete its travel cycle within the available operator handling time. To accomplish its task, the work station belt must be many times faster than the speed of the belt on the fusing machine. A transfer conveyor is therefore required between the loading station and the fusing machine for smooth transition. This transfer belt receives the part to be fused from the loading station at high speed but transfers it to the fusing machine at slow speed during the time the loading station belt is stopped for placement of the part. In order to ensure efficient transfer of the parts being fused, the electronic control of the transfer belt is linked to the speed control of the fusing machine. The transfer belt automatically adapts to any belt speed of the fusing machine.

V-AST Lay-up Stacker

Improve your fusing process

Achieving high quality and careful treatment of the fused parts is important. After fusing, the fused parts are transferred via the cooling belt to a transfer belt. This transfer belt separates the parts for safe stacking.



Advantages

- The stacker can be individually adapted to the width of the fusing machines as well as to the production process. The stacker is divided into lanes, which work independently from each other. Every operator has their own lane and can concentrate completely on their bundle.
- The number and the width of the lanes can be planned individually within the total working width.
- Using an optical sensor, the length of the fused part is automatically recognized. The stacker table will move out according to this information, to a position slightly below the transfer belt. The fused part is stacked and the table returns back to its original position. The stacker lanes adjust automatically to parts with different lengths.
- A scanner controls the stacking height, up to a maximum of 150 mm. As the table lowers (relative to the thickness of the part), an audible buzzer alarm sounds when the maximum stacking height is reached. It is also shown on the display.

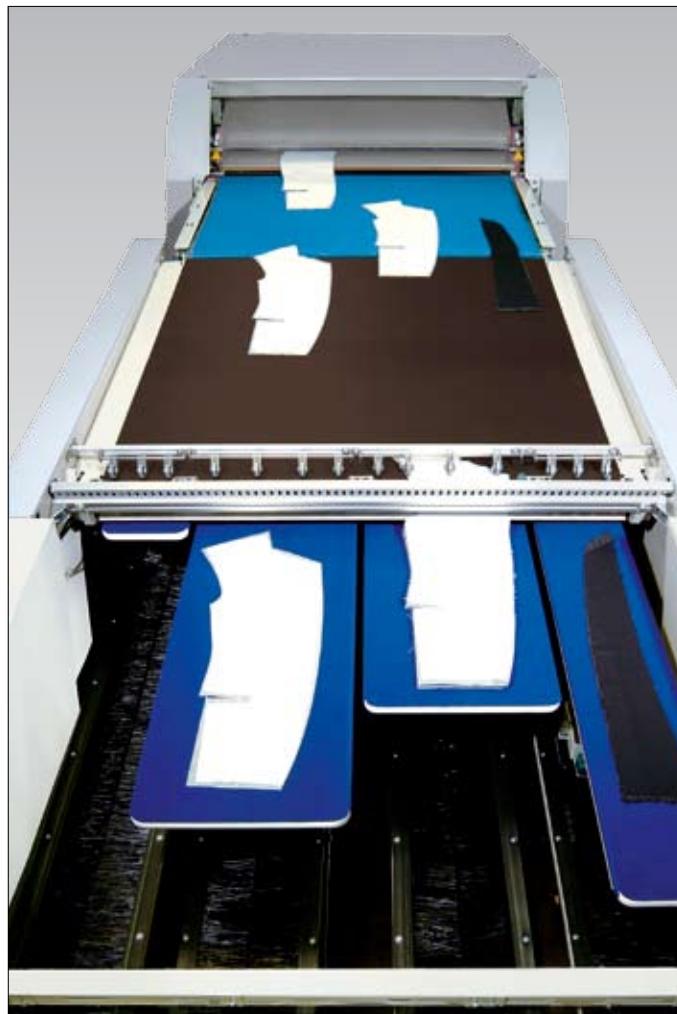

- By pressing a button on the display, the finished parts which have to be unloaded can be easily accessed. This button makes the lane move out from the machine for easy unloading.
- All lanes work independently from each other ensuring that the highest output can be achieved on each lane separately.
- Adjoining lanes can be coupled in order to finish larger parts or for block fusing. This coupling is carried out electro-pneumatically by pressing a button on the display.
- Small pressure rollers hold the finished parts as they enter the stacker, in order to avoid folding or creasing.

Fuse Master BX Series

The new Fuse Master BX series

The new Fuse Master BX series is a robust and reliable technology at an economical price. The series consists of a fusing machine with a width of 600 mm / 23.62 inch (BX 600) and a fusing machine with a width of 1000 mm / 39.37 inch (BX 1000). These fusing machines have an 800 mm / 31.5 inch long heating zone which is suitable for mixed productions. The temperatures for upper and lower heating zone can be adjusted separately and precisely for face fabric and interlining. For this reason, even sensitive fabrics can be fused without problems. The fusing belts are controlled proportionally for careful handling. The reliable surface contact heating elements, which maintain the exact temperature, provide a constant fusing result.



The control panel

The BX series has a user friendly panel to adjust and control all fusing parameters. In addition, a diagnostic system checks important machine parameters.

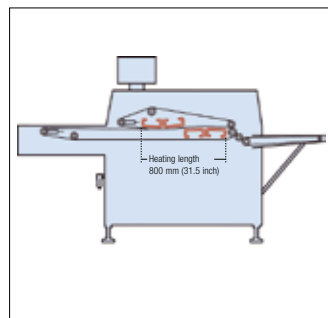

Functional description

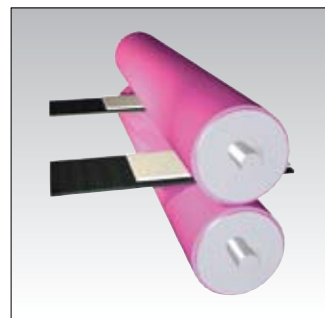

The pressure system

The BX models have been equipped with the reliable VEIT KANNEGIESSER standard pressure system. This pressure system is created for a wide range of fabrics (from sensitive face fabrics to popeline for shirts).

With the BX pressure system there are two choices of pressure shaft. For outerwear BX 1000 O and for shirts BX 1000 S. The difference is the coating of the pressure roller, as this has to be considered relevant to the type of inlay and adhesive.

AX 450 – The Reliable Solution

AX 450

The compact multi-purpose fusing machine AX 450 is the ideal solution for fusing a wide variety of interlinings and face fabrics. One side of the AX 450 is open to allow partial fusing. This is particularly useful for fusing of smaller areas on larger fabric pieces. The working width of 450 mm is, however, sufficient for fusing of front panels of a jacket or other larger components. The machine is equipped with two separate arched upper and lower heating zones which heat-up the synchronised driven belts. The temperature adjustment is infinitely variable. The pressure device is mechanically adjustable and ensures optimum bond strength between interlining and fabric.



Winding and Unwinding Device single and double

The winding and unwinding device for waistband fusing offers efficient operation from roll to roll.

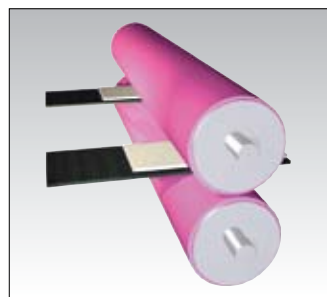

The pressure system

A spring-loaded pressure system allows the AX 450 to operate independent from the air supply or hydraulics. The specific fusing pressure is infinitely adjustable up to a maximum value of 33 N/cm². For fusing of pressure sensitive fabrics without linear pressure, the silicone coated pressure rollers can be set with a corresponding gap.



The control panel

A remarkable feature in this machine of this class is the precise control of the essential parameters:

- Monitoring of heating system
- Monitoring of belt control
- Monitoring of drive motor
- Monitoring of set and actual temperature

The control panel instantly shows any irregularities in these processes in order to avoid incorrect fusing and time-consuming trouble shooting.

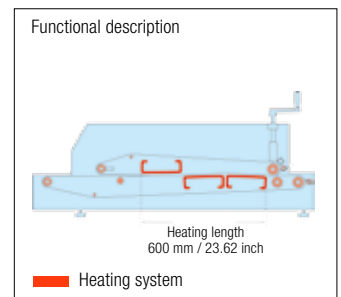

AX 450 – Options

Base Frame

The machine frame can be fitted with height adjustable legs or optional transport wheels for easier moving of the AX 450.

Unloading Slide

The exit of the AX 450 can be equipped with an unloading slide for easy removal of the fused parts.



Support for Creasing Devices

A special support for fixing attachments can be assembled to the attachment guidance.

CH 600 – Fusing Machine with integrated Cooling System

CH 600

The CH 600 with integrated cooling system and high pressure system is especially suitable for fusing of shirts and blouses. This machine can be operated by only one person.



Advantages:

- The surface contact heating element with a length of 600 mm avoids overheating and is material friendly for cuff and collar fusing.
- The separately adjustable upper and lower heating zones generate different temperatures for face fabric and interlining.
- The active cooling system accelerates the connection between interlining and face fabric and avoids a distortion of the fused parts.
- The pneumatic pressure system ensures constant pressure across the whole surface for all kinds of face fabrics.
- The automatic stacker device CH-ST 600 provides gentle and mark-free stacking.
- The automatic cleaning mechanism for the cover belt prevents contamination by excess glue.

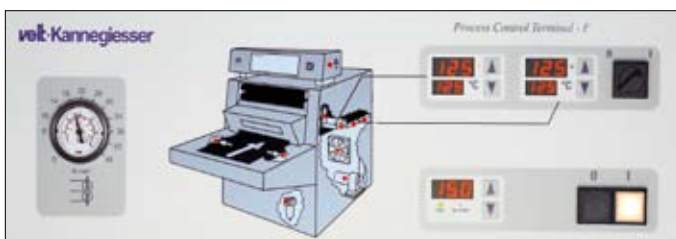

Control system

The process control terminal (PCT) guarantees easy operation and monitoring of the machine.

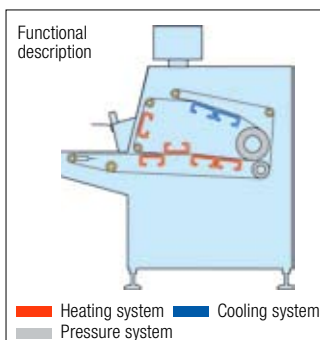

Heating system Cooling system
Pressure system

Hydraulic Presses

The hydraulic presses are particularly robust and only require minor maintenance. These presses with very high pressure systems are used for fusing of formal shirts and blouses. The HKZ is suitable for medium-sized productions with a wide range of interlinings. The HKH has been designed for larger productions. Only an electrical connection is necessary for the installation.

Advantages of HKZ

- Heating Plate: The heating plate guarantees an intensive heat transfer with an accurate and reliable temperature control. The heating plate is freely suspended and does not transmit any heat onto the machine frame.
- Heating Plate: Colstar heating is supplied by the plate mounted under the fusing area with the padded plate above. Adhesives migrate towards the heating source and this mounting technique ensures the highest quality bond values.
- Pressure System: Pressure is supplied by a reliable integrated hydraulic system that transfers pressure directly from the cylinder to the pressure plate. The plate is positioned for the best pressure distribution.

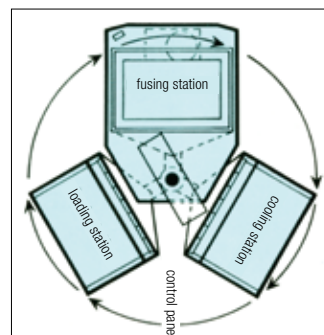

3-station design

Due to this installation, three processes always run simultaneously: As the operator unloads and then loads assemblies, fusing is done in the pressing station while cooling of the fused assemblies takes place in the third station. The rotating systems increase productivity and ensure a constant quality.

Hydraulic Presses

Advantages of HKH

- Heating System: The heating plate guarantees exact and reliable temperature control. This ensures intensive heat transfer and a high heat capacity.
- The Pressure System: The forming pressure is hydraulically controlled and generates an even pressure distribution.
- Cold Pressing Station: The cold pressing station consists of two water-cooled pressing plates. The fused assemblies are pressed between these cooled plates, reducing temperature rapidly to stabilise the fusing effect.
- Press Padding: The well-designed padding withstands both high temperature and extreme pressure for a long and trouble-free life span.
- Conveyor System: The conveyor system consists of a top and a bottom belt, guided on both sides by chains to avoid distortion. The lower belt transports the assemblies from the loading station, through the two pressing stations, to the unloading stations. The upper belt prevents shifting with light pressure, and keeps the parts from sticking to the top plate. Both belts are manufactured from adhesive-resistant materials.
- Low pressure device: A pressure range from 2-10 N/cm² can be adjusted with the optional low pressure device.

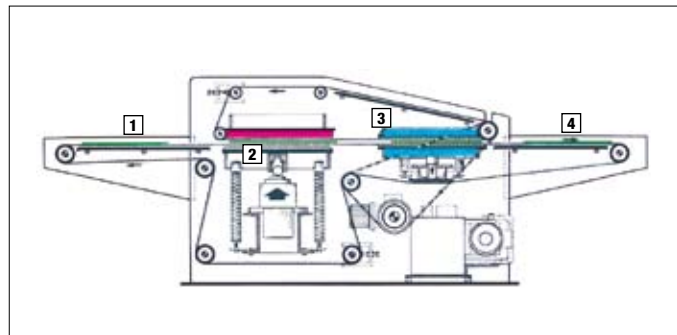

Control system

All control elements are centrally located, simple to use, and easy to read. The temperature control is a precision thermostat. Pressing time and cycle interval are controlled by the time switch, whereas, on demand, the sequence can be automated.

Functional description

- 1 loading
 - 2 adhesive
 - 3 cold pressing station
 - 4 unloading
- Plate heating
■ Water cycling cooling

Technical Data 1

Model	Usable working width mm (inches)	Operating speed m/min	Compressed air D=8 mm / 0.31 inch	Connected Load Volt / Hz/ kW	Dimensions		Consumption Compressed air l/min.
					W x L x H mm (inches)	Weight kg (lbs)	
Continuous fusing machines							
DX 1000 C	1000 (39.4)	1.7 - 10 (5,6 - 33)	6,5	3 x 400/50-60/23	1570(61.8) x 3000(118.1) x 1240(48.8)	1000 (2204.6)	50
DX 1000 CU	1000 (39.4)	1.7 - 10 (5,6 - 33)	6,5	3 x 400/50-60/23	1570(61.8) x 3160(124.4) x 1240(48.8)	1030 (2270.8)	50
DX 1000 CFC	1000 (39.4)	1.7 - 10 (5,6 - 33)	6,5	3 x 400/50-60/23	1570(61.8) x 3160(124.4) x 1240(48.8)	1030 (2270.8)	50
DX 1400 C	1400 (55.1)	1.7 - 10 (5,6 - 33)	6,5	3x400/50-60/30,5	1970(77.6) x 3000(118.1) x 1240(48.8)	1220 (2689.6)	50
DX 1400 CU	1400 (55.1)	1.7 - 10 (5,6 - 33)	6,5	3x400/50-60/30,5	1970(77.6) x 3160(124.4) x 1240(48.8)	1260 (2777.8)	50
DX 1400 CFC	1400 (55.1)	1.7 - 10 (5,6 - 33)	6,5	3x400/50-60/30,5	1970(77.6) x 3160(124.4) x 1240(48.8)	1260 (2777.8)	50
DX 1400 C/L	1400 (55.1)	1.7 - 10 (5,6 - 33)	6,5	3 x 400/50-60/42	1970(77.6) x 3550(139.8) x 1270(50)	1400 (3086.5)	50
DX 1400 CU/L	1400 (55.1)	1.7 - 10 (5,6 - 33)	6,5	3 x 400/50-60/42	1970(77.6) x 3725(146.7) x 1270(50)	1440 (3174.7)	50
DX 1400 CFC/L	1400 (55.1)	1.7 - 10 (5,6 - 33)	6,5	3 x 400/50-60/42	1970(77.6) x 3725(146.7) x 1270(50)	1440 (3174.7)	50
DX 1600 C	1600 (63)	1.7 - 10 (5,6 - 33)	6,5	3 x 400/50-60/48	2170(85.4) x 3550(139.8) x 1270(50)	1550 (3417.2)	50
DX 1600 CU	1600 (63)	1.7 - 10 (5,6 - 33)	6,5	3 x 400/50-60/48	2170(85.4) x 3725(146.7) x 1270(50)	1600 (3527.4)	50
DX 1600 CFC	1600 (63)	1.7 - 10 (5,6 - 33)	6,5	3 x 400/50-60/48	2170(85.4) x 3725(146.7) x 1270(50)	1600 (3527.4)	50
BX 600	600 (23.6)	1.7 - 10 (5,6 - 33)	6,5	3x400/50-60/10,8	1150 (45.2) x 3600(141.7) x 1500 (59)	520 (1146)	50
BX 1000	1000 (39.4)	1.7 - 10 (5,6 - 33)	6,5	3x400/50-60/17,5	1550 (61) x 3600 (141.7) x 1500 (59)	670 (1477)	50
AX 450	450 (17.7)	1.6 - 10 (5,2 - 33)	–	230/50-60/3,6	930(36.6)** x 2050(80)*** x 470(18.3)****	290/340* (638/748*)	–
CH 600	600 (23.6)	1 - 2.5 (3.3 - 8.25)	6,5	3 x 400/50-60/9,5	1060(41.7) x 1560(61.4) x 1550(61)	470 (1036.2)	1
				3 x 230/50-60/9,5			

MultiStar DX series: basic machine with cooling station; available working width with feeding station

* with base frame / ** without lateral guidance table / *** with entry table / **** AX 450 with and without base frame

Technical Data 2

Hydraulic presses						
Model	Height of work surface mm (inches)	Dimension pressplate mm (inches)	Compressed air D=8 mm / 0.31 inch	Volt / Hz/ kW	L x W x H mm (inches)	Weight kg (lbs)
HKZ 4/6,5	800 (31.5)	400(15.8) x 650(25.6)	–	3x400/50/7	2010(71.9) x 1920(75.6) x 1120(44.1)	720 (158.73)
				3x400/60/7		
				3x230/50/7		
				3x230/60/7		
HKH 5,6/7	770 (30.25)	560(22.1) x 700(27.6)	–	3x400/50/12,5	1350(53.2) x 3100(122.1) x 1070(42.1)	1450 (3196.7)
				3x400/60/12,5		
				3x230/50/12,5		
				3x230/60/12,5		

Workplace layout								
Model	Usable working width mm (inches)	Lengths of Work Area mm (inches)	Compressed air 6 bar D=8 mm / 0.31 inch	Connected Load Volt / Hz/ kW	Dimensions		Consumption	
					W x L x H mm (inches)	Weight kg (lbs)	Com-pressed air l/min.	Lane number
FE-L	950 (37.4)	3000 (117,9)	–	1x230/50– 60/0.25	1110(43.7) x 3130(123.2) x 850(33.5)– 950(37.4)	250 (551.2)	–	1
ET 4,5 / 14	450 (17.7)	1400 (55)	–	3x400/50–60/2	1200(47.2) x 3130(123.2) x 980(38.6)	300 (661.4)	–	2
V-AST 10	1000 (39.4)	–	4	3x400/50– 60/1.4	1430(56.3) x 3260(128.4) x 830(32.7)– 845(33.3)	820 (1807.8)	45	–
				3x230/50– 60/1.4				
V-AST 14	1400 (55.1)	–	4	3x400/50– 60/1.4	1855(73) x 3260(128.4) x 830(32.7)– 845(33.3)	920 (2028.3)	45	–
				3x230/50– 60/1.4				
V-AST 16	1600 (63)	–	4	3x400/50– 60/1.4	2030(79.9) x 3260(128.4) x 830(32.7)– 845(33.3)	1050 (2314.9)	45	–
				3x230/50– 60/1.4				

Workplace layout			
Model	Work width mm (inches)	Number of variants	Model versions mm (inches)
V-AST 10 / 50-50	1000 (39.4)	2	500(19.7) - 500(19.7)
V-AST 10 / 25-50-25	1000 (39.4)	3	250(9.8) - 500(19.7) - 250(9.8)
V-AST 10 / 40-30-30	1000 (39.4)	3	400(15.8) - 300(11.8) - 300(11.8)
V-AST 10 / 30-40-30	1000 (39.4)	3	300(11.8) - 400(15.8) - 300(11.8)
V-AST 10 / 30-30-40	1000 (39.4)	3	300(11.8) - 300(11.8) - 400(15.8)
V-AST 10 / 30-45-25	1000 (39.4)	3	300(11.8) - 450(17.7) - 250(9.8)
V-AST 10 / 25-45-30	1000 (39.4)	3	250(9.8) - 450(17.7) - 300(11.8)
V-AST 14 / 45-45-50	1400 (55.1)	3	450(17.7) - 450(17.7) - 500(19.7)
V-AST 14 / 50-45-45	1400 (55.1)	3	500(19.7) - 450(17.7) - 450(17.7)
V-AST 14 / 45-50-45	1400 (55.1)	3	450(17.7) - 500(19.7) - 450(17.7)
V-AST 14 / 25-45-35-35	1400 (55.1)	4	250(9.8) - 450(17.7) - 350(13.8) - 350(19.8)
V-AST 14 / 35-35-45-25	1400 (55.1)	4	350(13.8) - 350(13.8) - 450(17.7) - 250(9.8)
V-AST 14 / 35-45-35-25	1400 (55.1)	4	350(19.8) - 450(17.7) - 350(13.8) - 250(9.8)
V-AST 14 / 25-35-45-35	1400 (55.1)	4	250(9.8) - 350(13.8) - 450(17.7) - 350(19.8)
V-AST 14 / 25-45-45-25	1400 (55.1)	4	250(9.8) - 450(17.7) - 450(17.7) - 250(9.8)
V-AST 14 / 30-40-40-30	1400 (55.1)	4	300(11.8) - 400(15.8) - 400(15.8) - 300(11.8)
V-AST 16 / 30-50-50-30	1600 (63)	4	300(11.8) - 500(19.7) - 500(19.7) - 300(11.8)
V-AST 16 / 35-45-45-35	1600 (63)	4	350(13.8) - 450(17.7) - 450(17.7) - 350(13.8)
V-AST 16 / 40-40-40-40	1600 (63)	4	400(15.8) - 400(15.8) - 400(15.8) - 400(15.8)

Options DX Serie					
Model	Usable working width mm (inches)	Operating speed m/min (ft/min)	Connected Load Volt / Hz/ kW	L x W x H mm (inches)	Weight kg (lbs)
Feeding Station	1000 (39.4)	1.7 – 10 (5.6 – 33)	1x230/50–60/1*	1570(61.8) x 1400(55.1) x 310(12.2)	200
Feeding Station	1400 (55.1)	1.7 – 10 (5.6 – 33)	1x230/50–60/1*	1970(77.6) x 1400(55.1) x 310(12.2)	250
Feeding Station	1600 (63)	1.7 – 10 (5.6 – 33)	1x230/50–60/1*	2170(85.4) x 1400(55.1) x 310(12.2)	280
Feeding Station	–	–	–	1160(45.7) x 1000(39.4) x 19(0.8)	10

Technical Data 3

Model	Feeding Table	Feeding Station ¹⁾	Feeding System	Heating Arrangement upper/lower	Heating Arrangement lower/upper	Active Cooling	Return Feed System
DX 1000 C	+	+	+	+	+	+	+
DX 1000 CU	+	+	+	+	+	+	+
DX 1000 CFC	+	+	+	+	+	+	+
DX 1400 C	-	+	+	+	+	+	-
DX 1400 CU	-	+	+	+	+	+	-
DX 1400 CFC	-	+	+	+	+	+	-
DX 1400 C/L	-	+	+	+	+	+	-
DX 1400 CU/L	-	+	+	+	+	+	-
DX 1400 CFC/L	-	+	+	+	+	+	-
DX 1600 C	-	+	+	+	+	+	-
DX 1600 CU	-	+	+	+	+	+	-
DX 1600 CFC	-	+	+	+	+	+	-

¹⁾ not with table version

Model	Wiping Bar Transport Band	Automatic Cleaning System	Lateral Loading Table ¹⁾	Waistband Fusing	Insert Guide	Workplace Organisation
DX 1000 C	+	+	+	+	+	+
DX 1000 CU	+	+	+	+	+	+
DX 1000 CFC	+	+	+	+	+	+
DX 1400 C	+	+	+	+	-	+
DX 1400 CU	+	+	+	+	-	+
DX 1400 CFC	+	+	+	+	-	+
DX 1400 C/L	+	+	+	+	-	+
DX 1400 CU/L	+	+	+	+	-	+
DX 1400 CFC/L	+	+	+	+	-	+
DX 1600 C	+	+	+	+	-	+
DX 1600 CU	+	+	+	+	-	+
DX 1600 CFC	+	+	+	+	-	+

¹⁾ not with table version

Pressing for Excellence – Why you can put your trust in the VEIT-Group

For over 50 years, the requirements and the problems of our customers world-wide have been our most important challenge. For decades, world-famous brands in the German and the international garments industry have had confidence in the innovative, high-quality products and services of the VEIT-Group.



Our experts consult with you as a partner to assist you in finding the best solution for your project no matter if you are planning to use individual machines or if you need a complete production line.



Prompt delivery and professional installation of your machines and systems goes hand in hand with premium training with which we enable your staff to achieve the highest possible productivity.

Worldwide 24 hr Service Hotline

Our service technicians worldwide are available around the clock so that your production works with as little disruption as possible.



We look forward to dealing with you personally!

Your local sales agent:

VEIT GmbH

Justus-von-Liebig-Str. 15
D-86899 Landsberg/Lech
Germany
Tel. +49 (8191) 479-204
Fax +49 (8191) 479-199
E-Mail: info@veit.de
www.veit-group.com

BRISAY-Maschinen GmbH

Mittelweg 4
D-63762 Grossostheim-Ringheim
Germany
Tel. +49 (6026) 997-0
Fax +49 (6026) 997-100
E-Mail: info@BRISAY.de
www.BRISAY.com

KANNEGIESSER Garment & Textile Technologies GmbH & Co.

Valdorfer Strasse 100
D-32602 Vlotho · Germany
Tel. +49 (5733) 87 13-0
Fax +49 (5733) 87 13-45
E-Mail: info@veit-kannegiesser.de
www.veit-kannegiesser.com

